



MANUAL DE INSTALACION

Sistema de Enganche Reforzado ST5 SE100

Toyota SW4 Mod. 2016 +

1 CONTENIDO

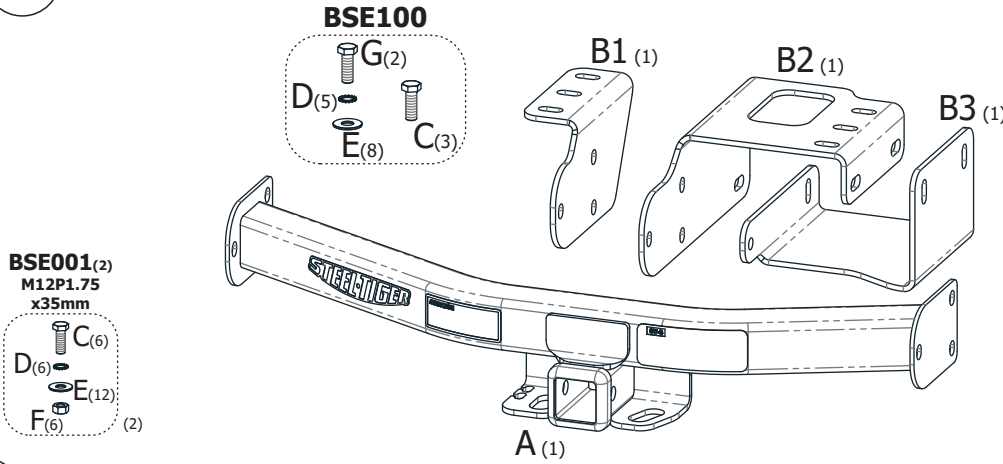

2 HERRAMIENTAS NECESARIAS

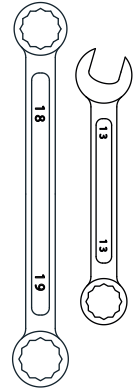

3 COLOCACIÓN DE PIEZAS "B1" Y "B2"

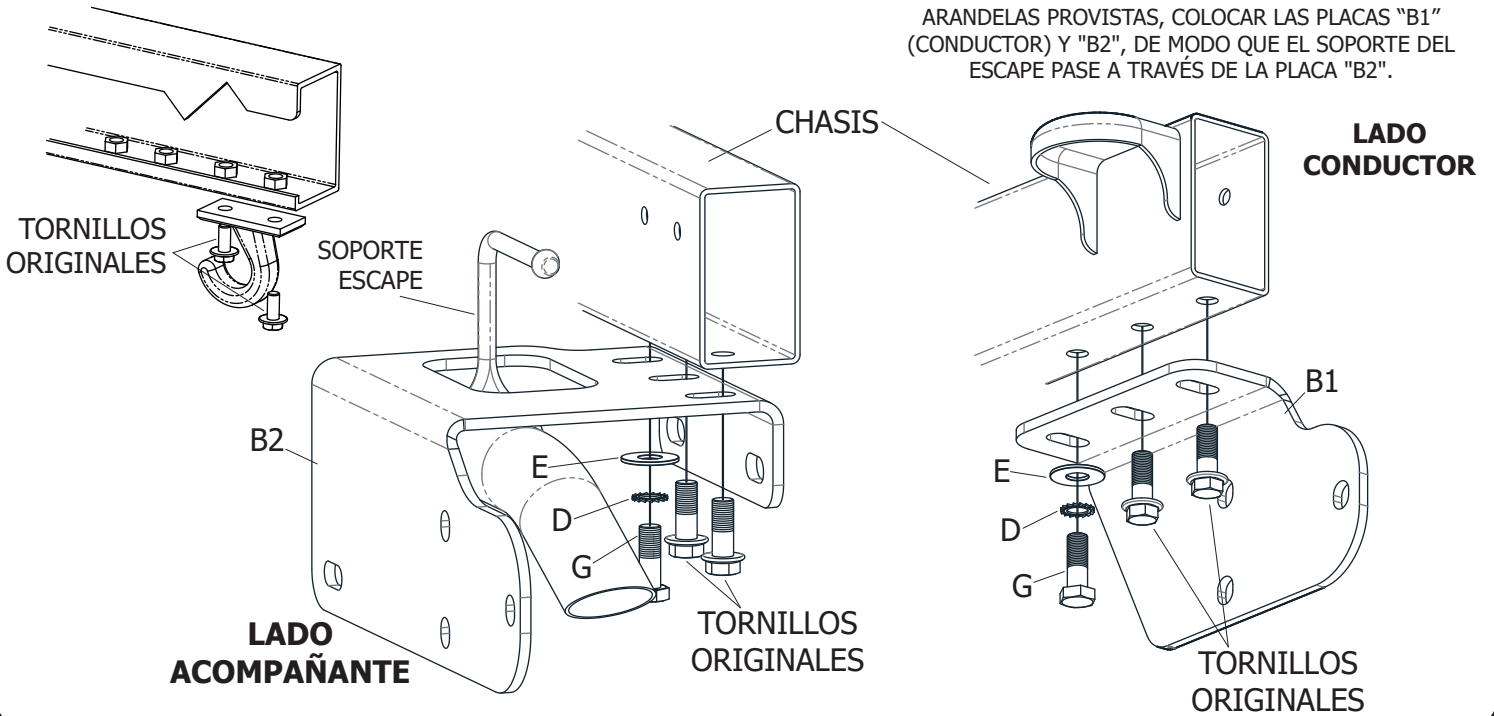

4 COLOCACIÓN DE PIEZA "A" Y "B3"

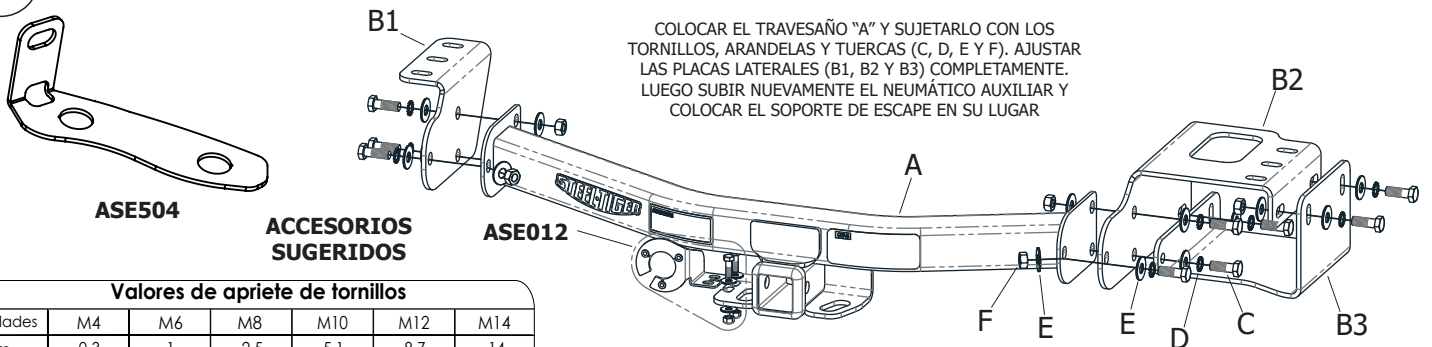

Valores de apriete de tornillos

| Unidades | M4 | M6 | M8 | M10 | M12 | M14 |
|-------------------------------------|-----|----|-----|-----|-----|-----|
| Kg.m | 0,3 | 1 | 2,5 | 5,1 | 8,7 | 14 |
| Coeficiente de fricción: $\mu=0,14$ | | | | | | |